

WD306



MAVIG

# Mobile X-Ray Protection WD306

With mobile shields, one must start with high expectations and goals during the conception and development stages in order to avoid it being a disturbance in the room. This is why all aspects of the work place must be taken into consideration in order to create a harmony between the equipment, procedural methods, and the demands of the personnel.

MAVIG produces mobile protection shields using the most modern materials available in many variations or according to customer specifications.

The WD306 with its large surface area and extensive lead acrylic top provides maximum protection and an unimpeded view for personal. The high-grade, electro-conductive wheels and sturdy side handles allow for easy and safe positioning.

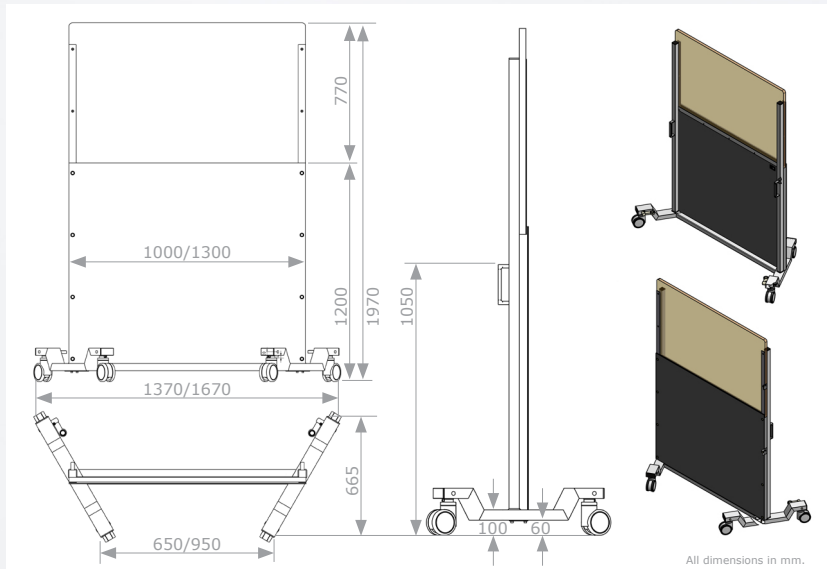

## Mobile Protective Shield

Article Number	Protective Area (WxH)	Dimensions* (WxHxD)	Lead Equivalent	Weight
WD306/1.0/1000	100 x 187 cm	137 x 197 x 66.5 cm	1.00 mm Pb	105 kg
WD306/1.0/1300	130 x 187 cm	167 x 197 x 66.5 cm	1.00 mm Pb	127 kg

*Special dimensions on request.*

*\*Overall dimensions include base and electro-conductive casters/wheels.*

