

EN

GD60



Spring Arm (1240 mm)

Cardanic Joint

Monitor Support

for large screens up to 60" and a maximum weight load of up to 120.0 kg / 264.5 lbs

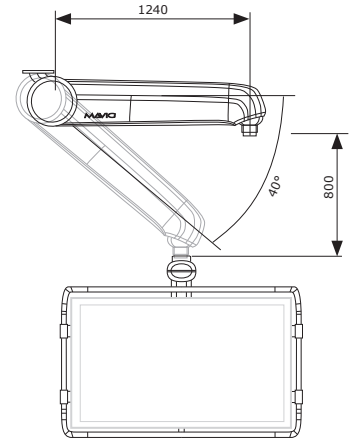
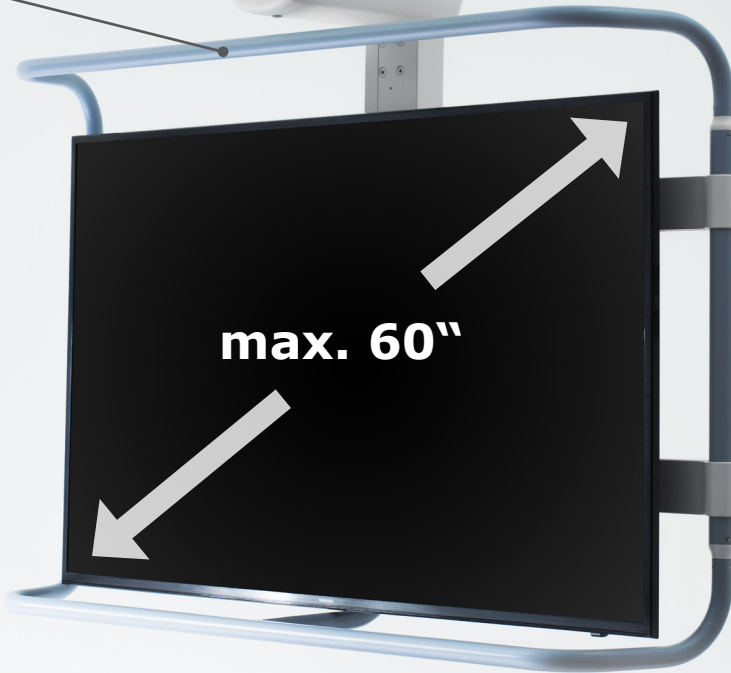

GD60 dimensions: Basic model with both spring arm versions (0° to 40° or +12° to -28°, see below)

WARNING: We recommend that before each installation, the ceiling is checked for sufficient load-bearing capacity! Installation should only be carried out by specialist personnel.



GD60 Rear view

Article-No.: **GD60W** (individual) The GD60 monitor suspension system is available in many different versions. The basic versions has a spring arm and monitor support for a large monitor up to 60" or 4 - 8 smaller monitors (with basic cabling options)

Made in Germany

GD60 – Versatile Suspension System for up to 8 Monitors

Our patented cardanic joint, automatic weight balancing, free-moving operation, as well as integrated cabling and the rapid installation of different monitor sizes are only some of the many features that distinguish the GD60. The system is designed for heavy load conditions, supporting a weight capacity of up to 120.0 kg / 264.5 lbs.

The suspension allows fast movements if the monitors have to move in an emergency. This reduces friction effects and prolongs the lifetime of the system.

- **Stationary mounted**
- **Long reach thanks to spring arm length of 1240 mm**
- **Heavy weight loads:** up to 120.0 kg / 264.5 lbs possible
- **Number of monitors:** depending on configuration 1 or 4 - 8 displays, monitor / display sizes up to 60" possible
- **Cardanic joint for more security in case of collision**

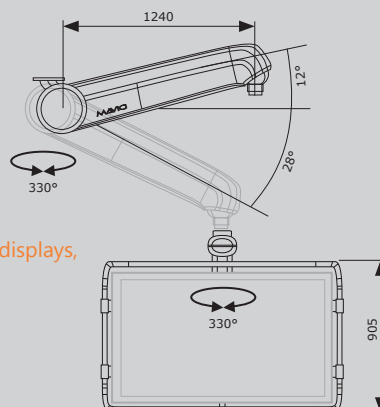

Other specific monitor support variations for the GD60, with different frame constructions, colours etc. (customer models: GE, Siemens, Philips, Dräger ...) available on request.

MAVIG GmbH
X-Ray Protection and
Medical Suspension Systems

Stahlgruberring 5
81829 Munich
Germany

Ti-Ba Enterprises, Inc.
MAVIG Representation
in USA and Canada

Phone +1-585 247 1212
Fax +1-585 247 1395
e-Mail mavigusteam@mavig.com